

Quad 2-input NAND gate

74F00

FEATURE

- Industrial temperature range available (-40°C to +85°C)

TYPE	TYPICAL PROPAGATION DELAY	TYPICAL SUPPLY CURRENT (TOTAL)
74F00	3.4ns	4.4mA

PIN CONFIGURATION

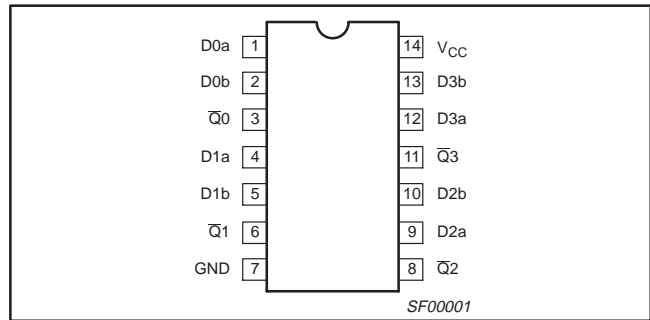

ORDERING INFORMATION

DESCRIPTION	ORDER CODE		PKG DWG #
	COMMERCIAL RANGE $V_{CC} = 5V \pm 10\%$, $T_{amb} = 0^{\circ}C$ to $+70^{\circ}C$	INDUSTRIAL RANGE $V_{CC} = 5V \pm 10\%$, $T_{amb} = -40^{\circ}C$ to $+85^{\circ}C$	
14-pin plastic DIP	N74F00N	I74F00N	SOT27-1
14-pin plastic SO	N74F00D	I74F00D	SOT108-1

INPUT AND OUTPUT LOADING AND FAN OUT TABLE

PINS	DESCRIPTION	74F (U.L.) HIGH/LOW	LOAD VALUE HIGH/LOW
Dna, Dnb	Data inputs	1.0/1.0	20µA/0.6mA
\bar{Q}_n	Data output	50/33	1.0mA/20mA

NOTE: One (1.0) FAST unit load is defined as: 20µA in the high state and 0.6mA in the low state.

LOGIC DIAGRAM

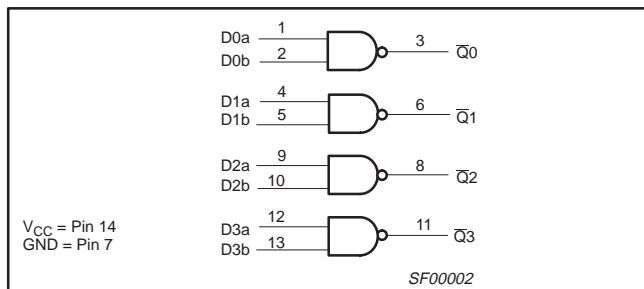

FUNCTION TABLE

INPUTS		OUTPUT
Dna	Dnb	\bar{Q}_n
L	L	H
L	H	H
H	L	H
H	H	L

NOTES:
H = High voltage level
L = Low voltage level

LOGIC SYMBOL

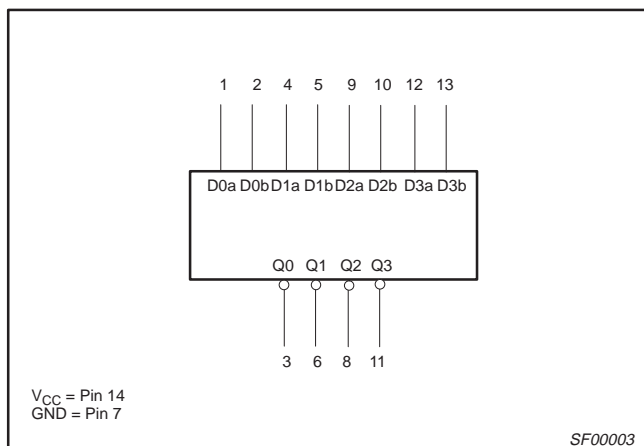

IEC/IEEE SYMBOL

